



NEW

iwis solutions for cup filling machines



In the **food industry**, flexible and highly efficient pots filling machines are used to automatically and precisely fill milk and milk-based products such as yoghurt into pots. Cup filling machines use **stainless steel chains with cell plate adjusters** to convey the cup filling containers in order to position pots and trays under the dosing mechanism with pinpoint accuracy.

iwis offers reliable and durable **CF stainless steel chains** to meet this challenge. **Maintenance-free JWIS CF-b.dry stainless steel chains** are an innovative development.

iwis industry solutions





Ultimate length precision

Intelligent, sterile filling machines use stainless steel roller chains with special attachments: These not only ensure that cups and trays are positioned under the dosing mechanism with pinpoint accuracy, but also guarantee safe and hygienic conveyance of the cups and trays through the infeed, sterilisation and sealing stations, quality control and final packaging.

Accurate parallel running coupled with **extreme length precision** of the stainless steel chains are crucial for **optimum positioning accuracy** of cups and trays in the production process. At the same time, we placed special emphasis on increased service life during development. The result is precise and reliable stainless steel chains, optionally available with initial lubrication that has been tested and approved for use with food applications by the NSF.

Highlights

- Ultra-precise positioning, greatest possible length precision and tightest tolerances across pairs of chains
- High resistance to corrosion
- **New:** Maintenance-free CF b.dry stainless steel chains from high-alloy stainless steel and completely hygienic. CF-b.dry stainless steel chains can be used absolutely dry.
- Optional: iwis offers a range of high-performance initial lubricants.
- Virtual or on-site customer support by iwis
- iwis CCM-S for chain condition monitoring and hence preventive maintenance

A **development partner and technology leader**, iwis is ready to tackle your challenges.



Your iwis segment manager

Abhijit Potdar

Key Account Manager

Tel. +49 89 76909-1449

Abhijit.Potdar@iwis.com



iwis vCard – Simply take a picture and automatically save the contact details!





Conveyor chains and attachment plates

Chain type	DIN ISO	Pitch p mm	Internal width b1 min. mm	Roller Ø d1 max. mm	Pin Ø d2 max. mm	Pin length a1 max mm	Effective pin length** a max. mm	Plate height g mm	Lateral pitch e mm	Breaking load iwis mean F_b N	Order no. chain without initial lubrication
Stainless steel range											
M 1611 CF*	16 B-1	25.40	17.02	15.88	8.28	36.1	41.5	21.0	–	40,000	40008157
Maintenance-free range											
M 1611 CF b.dry	16 B-1	25.40	17.02	15.88	8.28	36.1	41.5	21.0	–	40,000	40009453

** a = Connecting link with spring *CF = stainless

The bent attachment plates for the container holders can be fitted precisely at right angles at any interval required by the customer. The internal diameter of the **standard bent attachment plates** is **10.2 mm**.

As an option, the bent attachment plates can have a **10-mm hole**. iwis offers a range of high-performance lubricants.

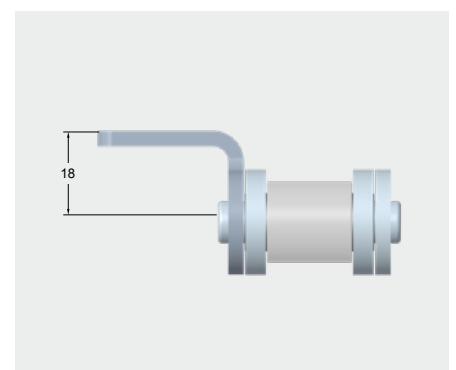
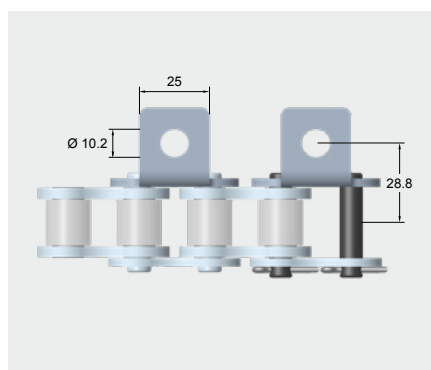
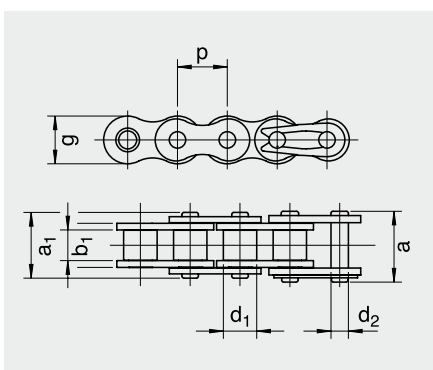

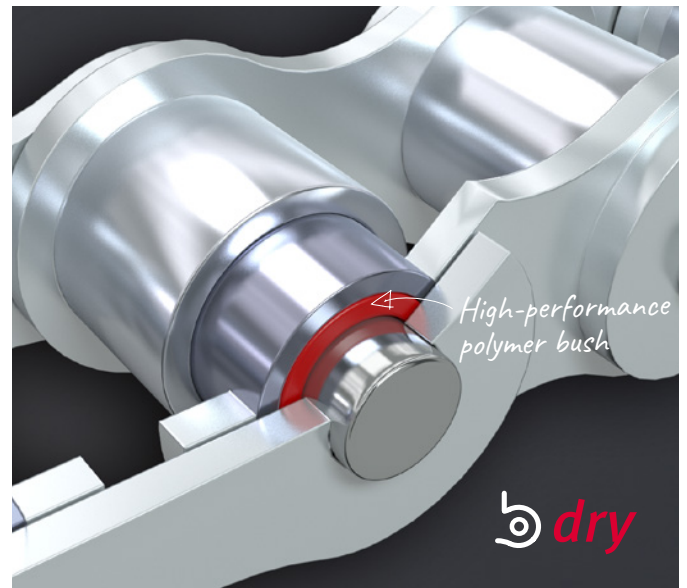
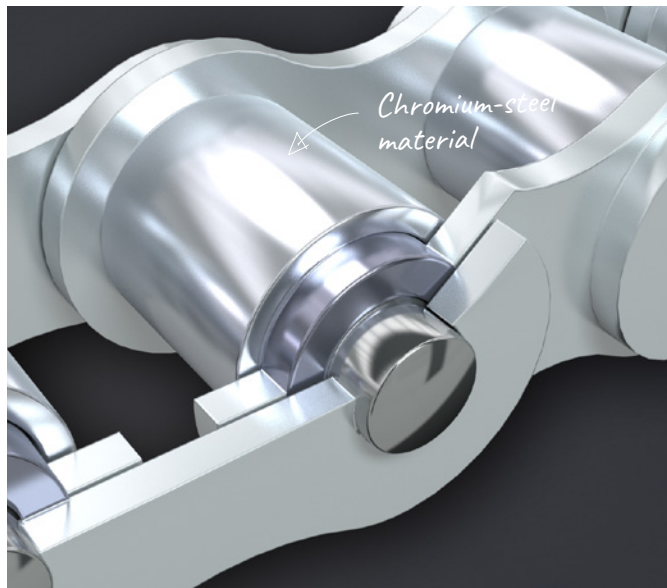

CF stainless steel chains

Corrosion-free chains at their best! Precision-manufactured individual parts counteract material-related constraints and ensure outstanding positioning accuracy, reliability and wear reduction.

Specially selected chromium steels ensure that the CF stainless steel chains have the best possible level of anti-corrosion protection. Alongside humidity, CF chains can also withstand **acids**, **alkalis** and even **extreme temperatures** from -80 °C to +400 °C! Stainless steel chains are at no risk from coating particles released through abrasion and are ideal **for sensitive applications and applications with high hygiene requirements.**

Applications

- For applications with exacting hygiene requirements
- For continuous contact with acids and alkalis
- In environments with extreme temperatures

CF-b.dry stainless steel chains

The **maintenance-free**, high-alloy chromium steel roller chains can be used **absolutely dry**. This is made possible by the special, high-performance polymer b.dry friction bearing in the chain link. This friction partner avoids steel-on-steel contact between the pin and bush. This means that you can use the chain without any lubricants throughout its entire service life. A ball-drilled steel carrier bush surrounds the friction bearing, giving the chain additional strength.

Applications

- Wherever relubrication is either undesirable or impossible
- In corrosive environments
- For use in sensitive and hygiene-critical applications (food processing)
- CF-b.dry chains are resistant to aggressive substances and can be used in temperatures ranging between -100 °C and +200 °C
- External factors, such as the temperature range or contact with chemical substances, etc., have a direct impact on the performance of mechanical elements.

For further information, see our product flyer or visit www.iwis.com



For further information, see our product flyer or visit www.iwis.com/bdry



Engineering

Elongation

Greater productivity and higher output rates have led to regular preventive maintenance on production equipment becoming a rarity. Which makes it all the more important to be able to rely on the durability and reliability of drive chains and conveyor chains.

We use a special pre-stretching process to reduce the initial run-in elongation in order to allow simple, fast and accurate fitting of the chains. We optimize wear elongation by a combination of ideal material pairings, high manufacturing precision and maintenance-free components.

Our maintenance-free roller chains also prevent corrosion and stiffening.

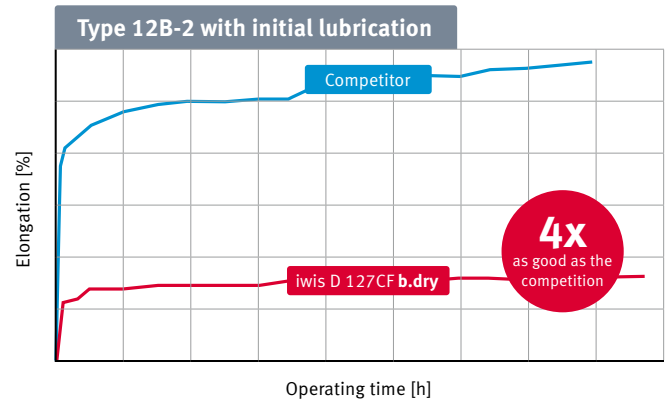

Positioning / Accuracy

Filling machines require the use of roller chains with strict length tolerances: The high-precision parallel operation of a pair of chains ensures exact positioning of the attachments in relation to each other.

In this regard, DIN ISO 606 defines that chains must be manufactured within a tolerance of **+0 to +0.15 %** in respect of the nominal length at a defined measuring force and length. For a 5 m standard length, this means possible length discrepancies of up to 7.5 mm.

Using a special manufacturing process, we can reduce this tolerance in our JWIS stainless steel chains even further, down to **0.075 % of the nominal length**, and thus achieve the highest possible precision in a roller chain.

With two parallel chain strands, we can also achieve parallel running accuracy of **up to 0.5 mm** – regardless of the total length – and thus ensure precise positioning.

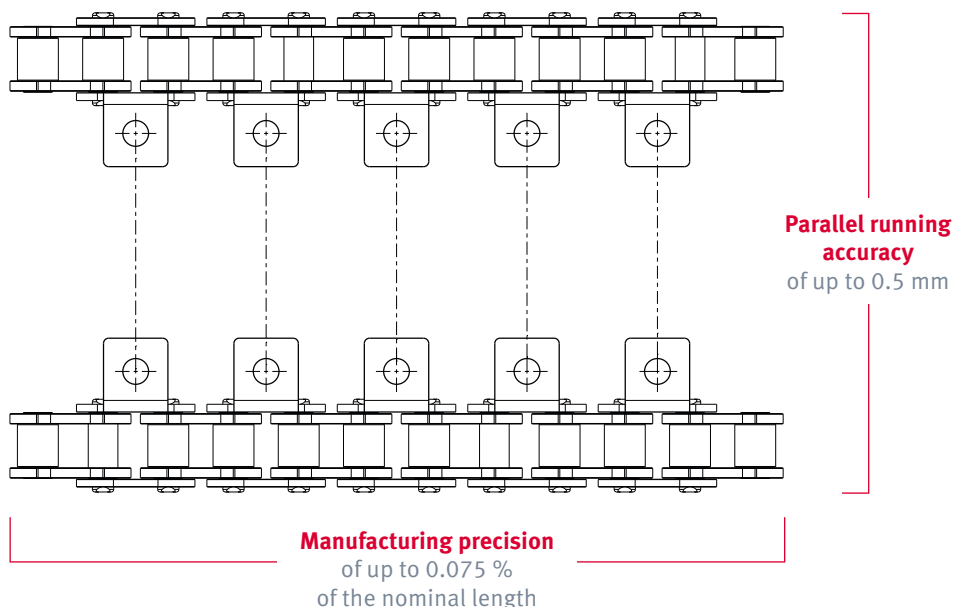

Chain lubrication

Because most of the friction is generated in the chain link joints, lubrication of this location has a decisive impact on the service life of a chain drive. In filling machines, the use of food-grade lubricants depends on factors such as the accessibility of plant equipment, maintenance intervals, the risk of contamination and the intensity of cleaning. When selecting the correct lubricant, it is also important to consider the media with which the chain comes into contact in the application.

Residue from milk products and cleaning agents can penetrate the chain link joint, and this can take lubricant from the chain and/or have an abrasive effect. This can result in inefficient relubrication and stiffness in the chain link joints. In this type of application, **JWIS CF stainless steel chains can receive an initial lubrication with iwiDUR** high-performance wax, for instance.

Depending on the conditions of use, we recommend the following **lubricants**:

Initial lubricant iwiDUR®

New generation wax lubricant for the food industry with NSF H1 approval

iwiDUR (EL-6) is a lubricating wax for chains. It is introduced into the chain link in a special warm submersion process at iwis. This product has been specially developed for initial lubrication of chains. It offers excellent wear protection and good corrosion resistance. iwiDUR is not restricted to the food industry; it is also used in many other sectors, such as medical engineering.

Technical data:

Structure	Highly viscous
Colour	Beige
Viscosity	approx. 125 mm ² /s at +100 °C
Density	approx. 0.89
Service temperature	-25 °C to approx. +80 °C (change of state)
NSF H1 approval	no. 154890

Relubrication

Our high-adhesion **VP8 FoodPlus Spray** is ideal for relubrication. It goes without saying that this lubricant meets the stringent requirements of NSF H1 and is thus approved for use in the food industry.

Furthermore, our **MEGALife** and **CF b.dry** maintenance-free chains permit a remarkable service life without any initial lubrication or relubrication (**dry running**).



NEW VP8 FoodPlus Spray

- NSF H1 food grade approval (no. 157999)
- Free of MOSH/MOAH
- Precise, economic application possible
- Optimum penetration of chain link joint
- Temperature range of -35 °C to +135 °C
- Free of animal products and ethanol
- Silicone-free

For more information, see our flyer
"Lubrication Solutions from iwis"



iwis Services: Close to the customer



On-site advice and assessment

- Complete chain appraisals and plant analysis
- Expert experience and recommendations
- Application-specific solutions

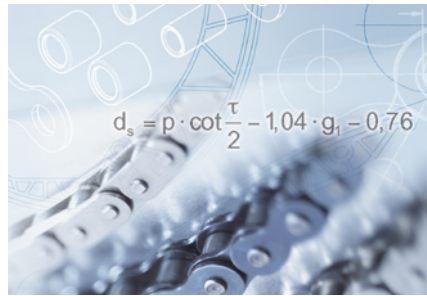

Technical support

- Chain drive configuration
- Endurance tests and benchmarking
- Fatigue strength, breaking strength and metallographic analyses
- 3D printing models
- Technical documentation

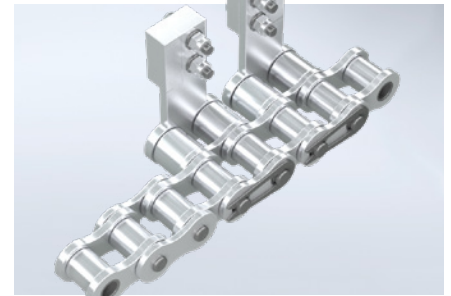

Tailored solutions

- Wide variety of options for mounting attachments
- New design and optimization of attachments
- Customer-specific article labelling



CCM-S condition monitoring

Chain elongation monitoring system as a perfect preventive maintenance tool.



CLA lubrication system

The new CLA lubrication system from iwis ensures a long chain service life economically, cleanly and with absolute precision.



Online tools

- CAD drawings
- Chain finder
- Chain configurator



Drive components

- Sprockets
- Plate wheels
- Chain tensioners

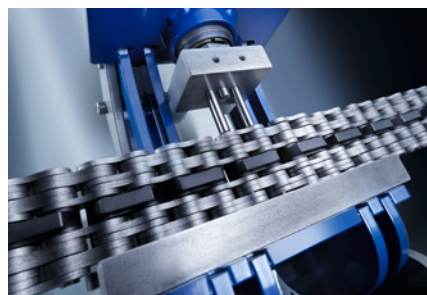

iwiTools

- Chain breaking tools
- Chain pullers
- Pin extractors



Customer Service

Tel. +49 (0)89 76909-1600
Fax +49 (0)89 76909-1198
sales-muenchen@iwis.com

Our subsidiaries

Germany

iwis antriebssysteme GmbH & Co. KG
Albert-Roßhaupter-Straße 53
81369 München
Tel. +49 89 76909-1600
Fax +49 89 76909-1198
sales-muenchen@iwis.com

Germany

iwis antriebssysteme GmbH
Essener Straße 23
57234 Wilnsdorf
Tel. +49 2739 86-0
Fax +49 2739 86-22
sales-wilnsdorf@iwis.com

Germany

iwis agrisystems
Schützenweg 5
36205 Sontra
Tel. +49 5653 9778-0
Fax +49 5653 9778-26
agrisystems@iwis.com

Brazil

iwis Sistemas de Transmissão
de Energia Mecânica Ltda.
Rua Bento Rosa, nº 1816
Bairro Hidráulica
95.900-000 Lajeado, RS
Tel. +55 51 3748-7402
salesbrazil@iwis.com

China

iwis drive systems (Suzhou) Co., Ltd.
No. 266 LvliangShan Road
215153 Suzhou SND
Tel. +86 512 8566-3010
Fax +86 512 8566-3009
salescn@iwis.com

France

iwis systèmes de transmission
10, rue du Luxembourg
69330 Meyzieu
Tel. +33 4374515-70
Fax +33 4374515-71
salesfr@iwis.com

Great Britain

iwis drive systems Ltd.
Unit 8c Bloomfield Park
Bloomfield Road, Tipton
West Midlands, DY4 9AP
Tel. +44 12 15213600
Fax +44 12 15200822
salesuk@iwis.com

India

iwis drive systems India Pvt. Ltd.
„Anisha“, Unit No3, SR. No. 84/1
Regency Cosmos, Baner Mahalunge Road,
Opposite to Amruta Hotel
Baner, Pune, Maharashtra-411045
Tel. +91 20 67110305
salesin@iwis.com

Italy

iwis drive systems Srl
Via Carlo Rota, 10
20090 Monza (MB)
Tel. +39 340 9296142
Fax +49 89 7690949-1726
italia@iwis.com

Canada

iwis drive systems, Inc.
101-19097, 26th Avenue,
Surrey BC V3Z 3V7
Tel. +1 604 560-6395
Fax +1 604 560-6397
salesca@iwisusa.com

South Korea

iwis engine systems Korea Co., Ltd.
Office No. 403-2, 322 Yanghyeon-ro
(Yatap-dong, Korea Design Center)
Bundang-Gu, Seongnam Si,
Gyeonggi-Do, Korea (ZIP) 13496
Tel. +82 31 788-7545
saleskor@iwis.com

Switzerland

iwis AG Kettentechnik
Bahnweg 4 (Postfach)
5504 Othmarsingen
Tel. +41 62 8898999
Fax +41 62 8898990
info@iwis-ketten.ch

South Africa

iwis drive systems, (Pty) Ltd.
Unit 3, 127 Koornhof Road
Meadowdale, 1613
Tel. +27 11 392-2306
Fax +27 11 392-3295
salessa@iwis.com

Czechia

iwis antriebssysteme spol. s r.o.
Přísecká 893
38601 Strakonice
Tel. +420 383 411811
Fax +420 383 321695
salescz@iwis.com

Turkey

iwis tahrik sistemleri ltd. şti.
Kağıthane Ofis Park 4C-Blok
Bağlar Cad. No: 14
34406 Kağıthane-Istanbul
Tel. +90 212 939-3843
Fax +90 212 939-3701
salestr@iwis.com

USA

iwis drive systems, LLC
Building 100, 8266 Zionsville Road
Indianapolis, IN 46268
Tel. +1 317 821-3539
Fax +1 317 821-3569
sales-us@iwis.com

www.iwis.com

iwis
wir bewegen die welt

Your sales representative

