

**iwis mobility systems  
GmbH & Co. KG**

# **Complex Motion Systems**

October 2022 / Kai Arens

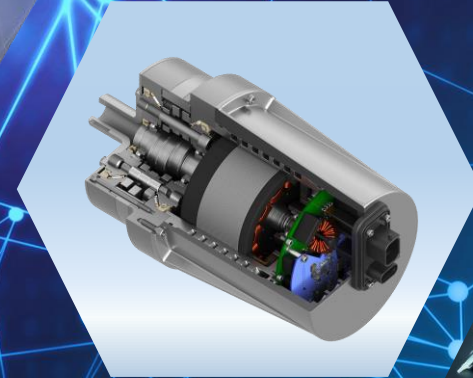
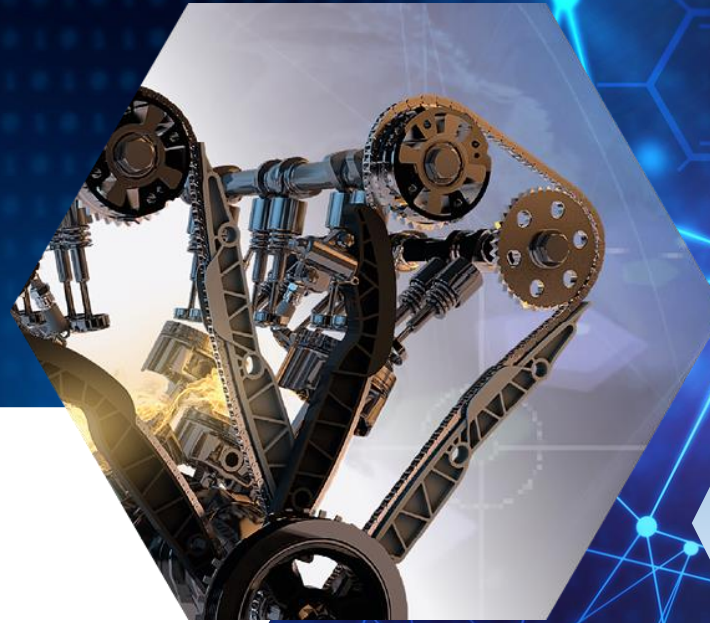

The basic structure of iwis is ....



33,3%

THIENeDrives

The logo for THIENeDrives, with "THIEN" in black, "e" in yellow, and "Drives" in black. To the right is a photograph of a precision-machined metal part on a production line.

**Division mobility systems**

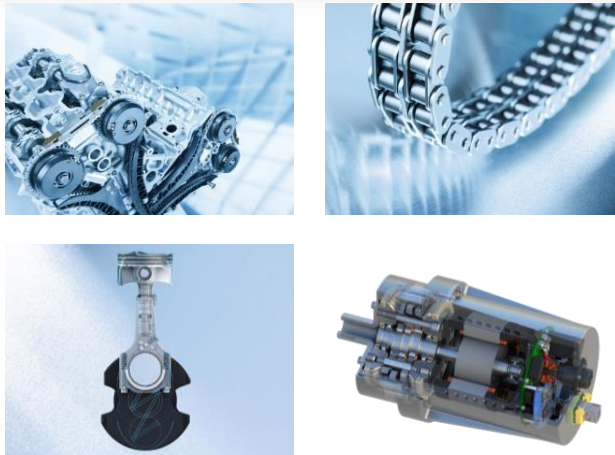

**Division drive systems**



**Division mechatronics**



# Customer structure

Strong foundation in automotive technology – at home in many industries

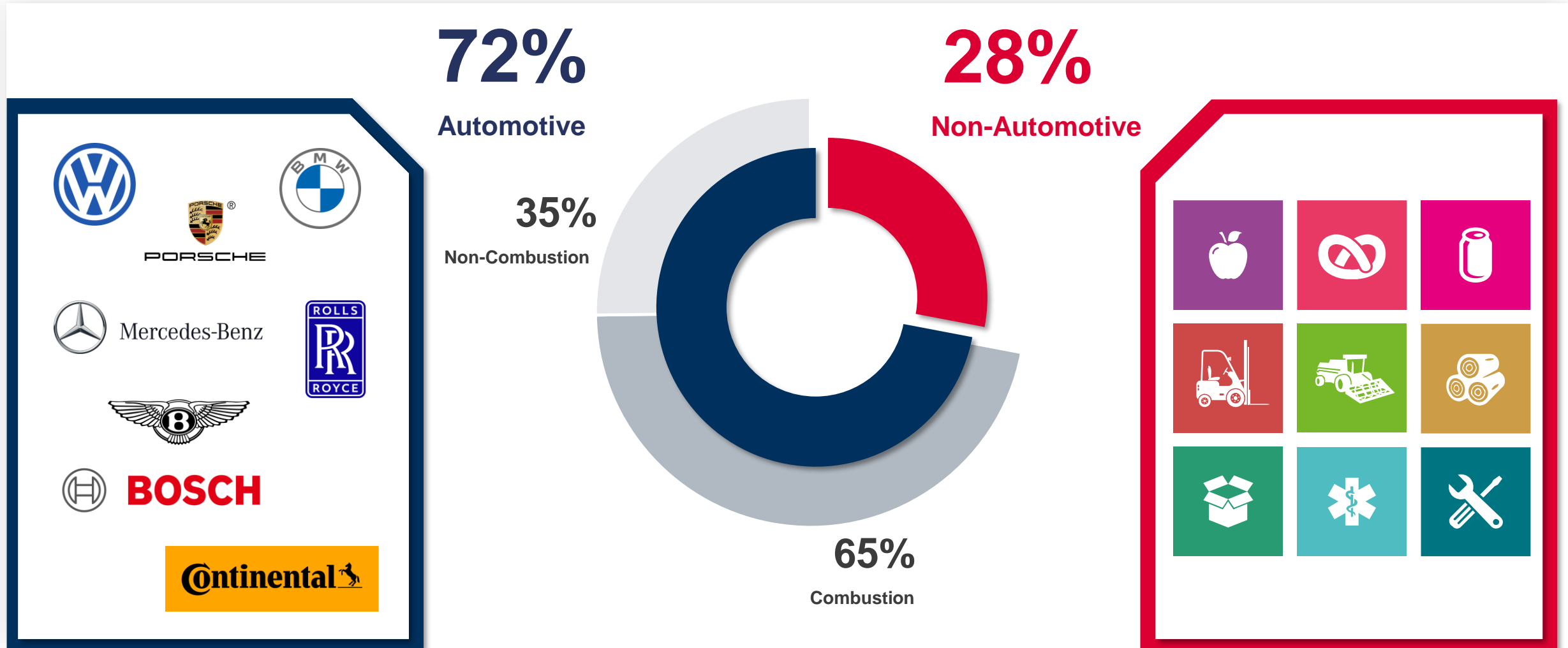

# Success in the group

Global player with local presence

**49**

locations globally

**3200**

employees



# Outlook

What drives the industry and how we can support



## E-MOBILITY



With products from the iwis group, we offer solutions for all relevant areas of an increasingly electrified and connected mobility.



High precision plastic-metal-assemblies with electronic contacting and connection technology



▪ Timing Chains



▪ System Parts



▪ Timing Drives



▪ Variable Compression Ratio System



▪ Aftermarket

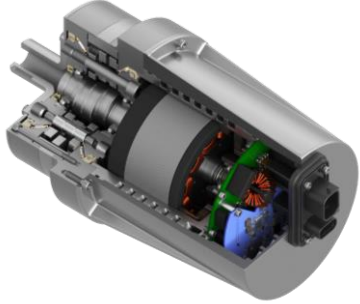

▪ Complex Motion Systems

## Timing Drive Systems for the Automotive Industry and Complex Motion Systems

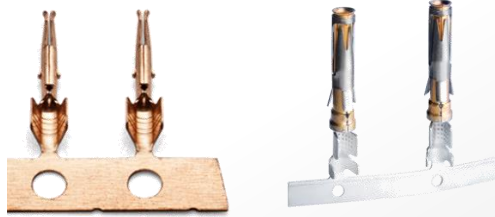

- Round contacts



- Housing



- Plastic-metal-assemblies with bondable surfaces



- Overmolded assemblies



- Assembled components

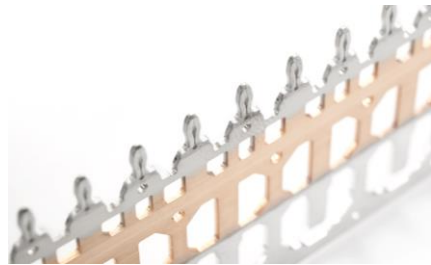

- Press-fit contacts



- Multi-component parts



- Hybrid assemblies



## First class products through excellent performance and technologies



- Roller chains



- Attachment chains



- Agri chains



- Sprockets



- Chain Condition Monitoring (CCM)



- Maintenance



- Direct Hybrid Manufacturing

# THIEN eDrives

iwis expansion towards BEV

„THIEN eDrives“ – iwis is one of 3 shareholders

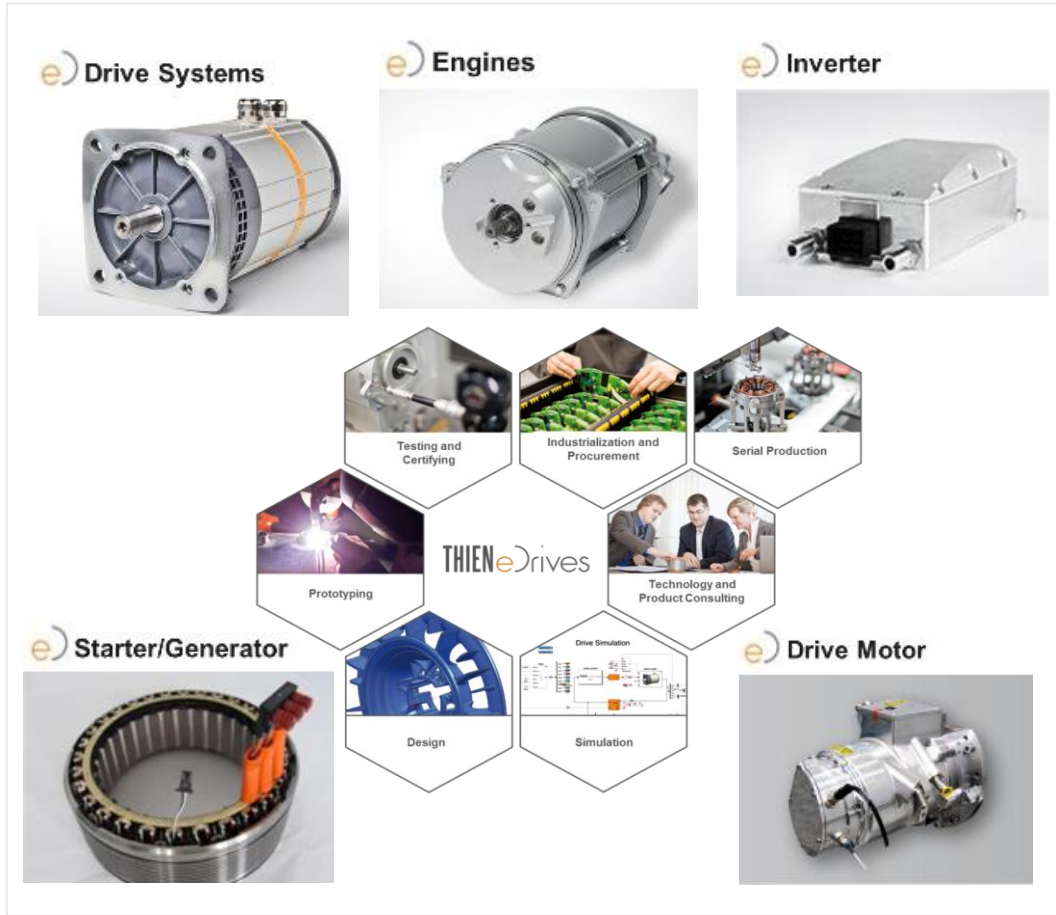

## Products with

- ✓ Highest efficiency
- ✓ Highest power density
- ✓ Special or smallest requirements of construction space
- ✓ Special environmental conditions
- ✓ ...

# THIEN eDrives

iwis expansion towards BEV

„THIEN eDrives“ – at home in many industries



Commercial vehicles



Pumps

Aviation



Renewable Energy



Machine tools



Automotive

Medicine technology



Fans



Agriculture



Marine

**Our Products** are always customer specific and never commodity catalogue goods.

## Kontaktperson:

THIEN eDrives GmbH

- Dr.-Ing. Armin Nickel (Sales Representative)
- [armin.nickel@thien-edrives.com](mailto:armin.nickel@thien-edrives.com)
- Tel.: +49 160 5536542

## „Experts in Automotive Inverter Technology – strong partnership as shareholder of THIEN eDrives

AVL covers all relevant competences to develop power electronics from idea to SOP

### Simulation & CFD

- EMC
- Electrical circuit
- Thermal

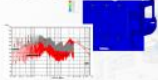

### Testing & Validation

- MiL, SiL, HiL
- PowerHiL
- Testbed
- DV/PV



### Engineering & Design

- Hardware
- Application & Basic Software
- Safety
- Security

### Prototyping

- Build-up
- Commissioning

### Industrialization

- Production engineering
- Support

### E-Axle integration solutions

provides a big step for compact design, robustness & further cost reduction

### AVL electric driveline competences for electrified vehicles

Engineering & development from concepts, components to prototyping and fully integrated E-Drive systems

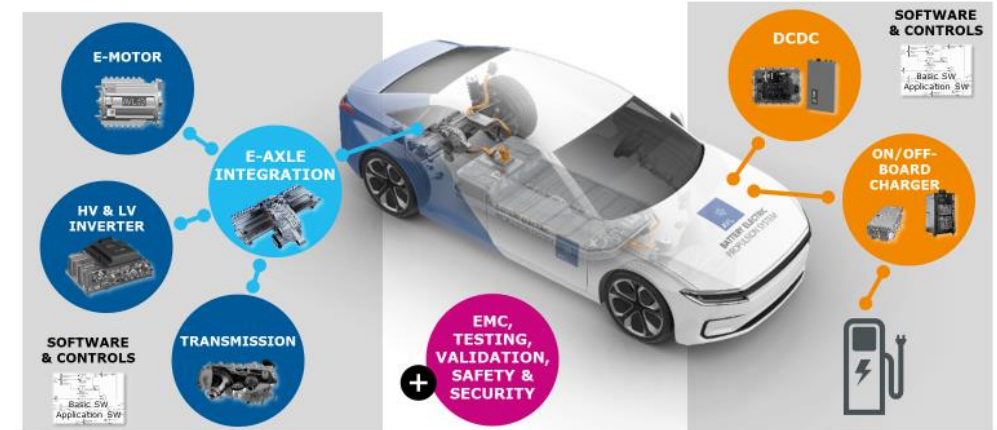

- ✓ The strong competences available at AVL complete the competence spectrum within the consortium to be able to offer all required solutions for complex motion systems with automotive requirements.

### Kontaktperson:

AVL Software and Functions GmbH

- Felix Emperhoff (Sales Engineer)
- [felix.emperhoff@avl.com](mailto:felix.emperhoff@avl.com)
- Tel.: +49 152 59963257

# High development competence within the Consortium

Competencies in Development, Industrialization and Production

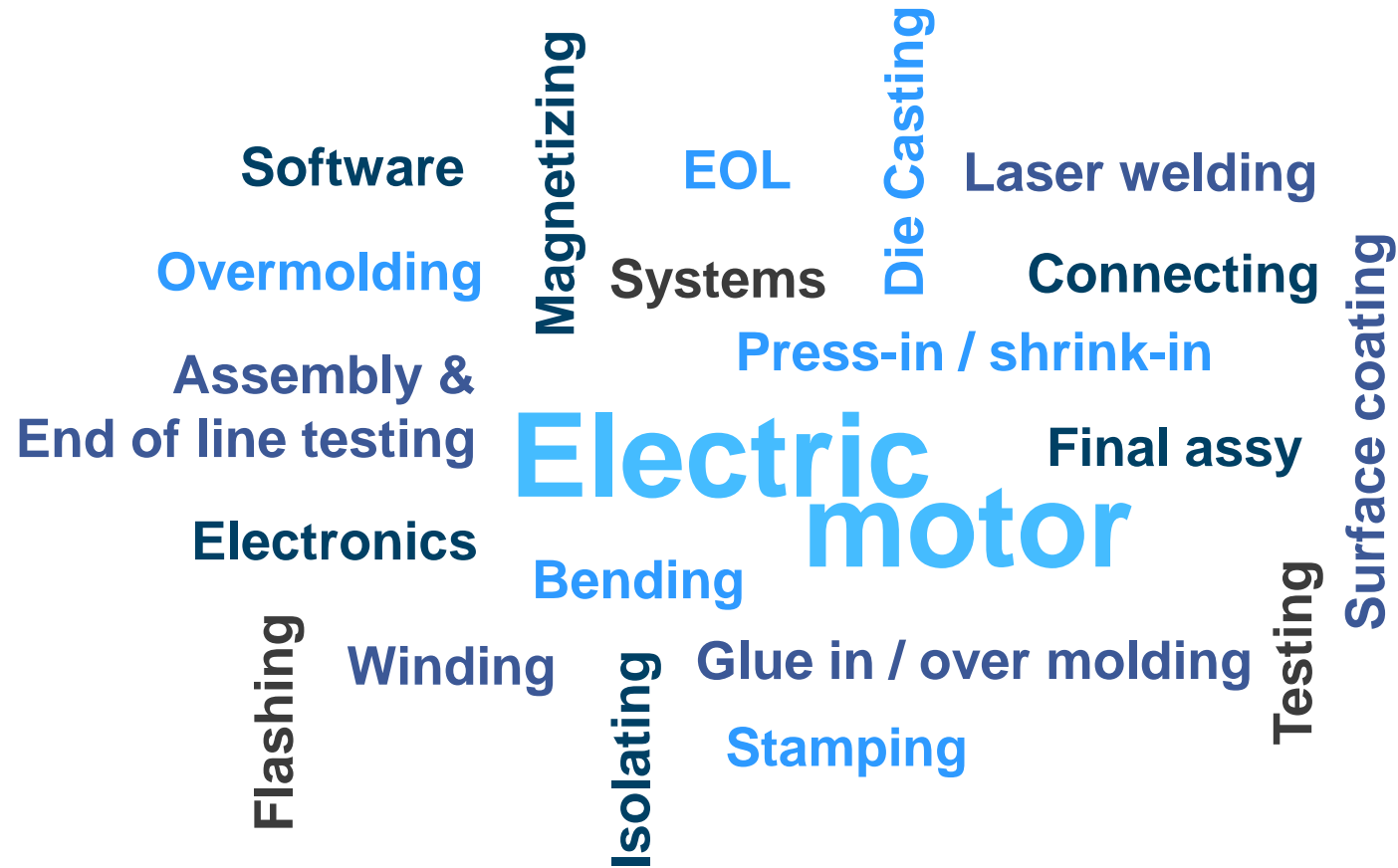

- ✓ We have **all required competencies** to develop complex motion systems according to the **highest customer specific standards!**

# High development competence within the Consortium

## Competencies in Development and Production

	Stamping	Bending	Overmolding	Die Casting	Systems	Assembly / End of line testing	Surface coating	Electronics	Software	Electric motor
<b>iwis</b> Development expertise	✓	✓	✓	✓	✓	✓	✓	✗	✗	✗
<b>iwis</b> Manufacturing expertise	✓	✓	✓	✗	✓	✓	✓	✗	✗	✗
THIEN eDrives Development expertise	✓	✗	✗	✓	✓	✓	✗	✓	✓	✓
THIEN eDrives Manufacturing expertise	✗	✗	✗	✗	✓	✓	✗	✓	✓	✓
AVL Development expertise	✗	✗	✗	✗	✓	✓	✗	✓	✓	✓

# High level of manufacturing expertise in large-scale automotive production

## Manufacturing

	Magnetizing	Glue in / over molding	Winding	Isolating	Connecting	Testing	Stamping	Laser welding	Press-in / shrink-in	Final assy	Flashing	EOL
<b>iwis</b>												
Manufacturing expertise	✗	✓	✗	✓	✓	✓	✓	✓	✓	✓	✗	✗
<b>THIEN eDrives</b>												
Manufacturing expertise	✓	✓	✓	✓	✓	✓	✗	✗	✓	✓	✓	✓

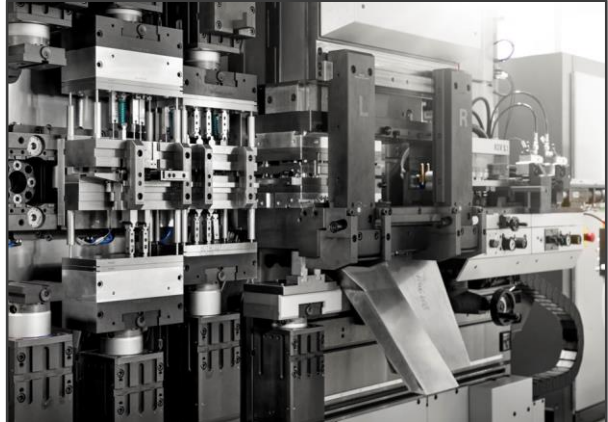
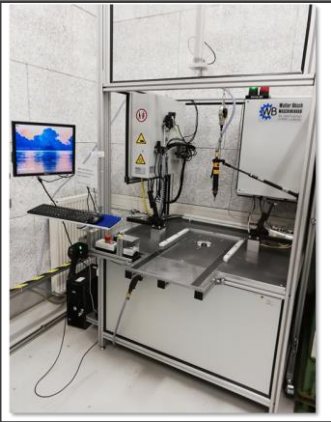

# iwis mobility systems GmbH & Co. KG

single parts and complex systems from the iwis group

Part



Sub-System



System

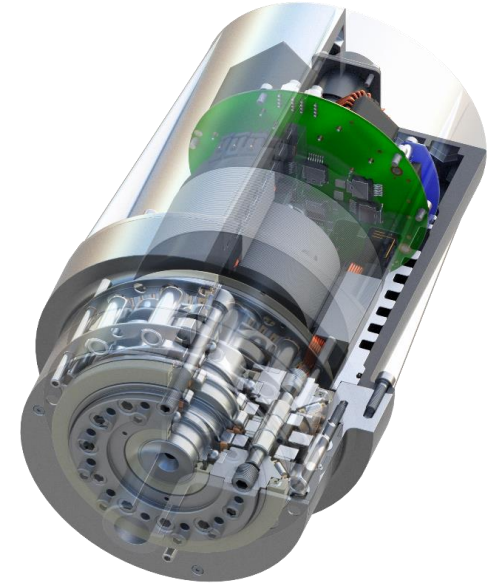

iwis utilizes the competencies inside the iwis group and their cooperation partners to provide a one stop solution for our customers. We provide solutions on all levels from single part to whole system!



# iwis mobility systems GmbH & Co. KG

Drive unit with e-motor, gearbox and inverter

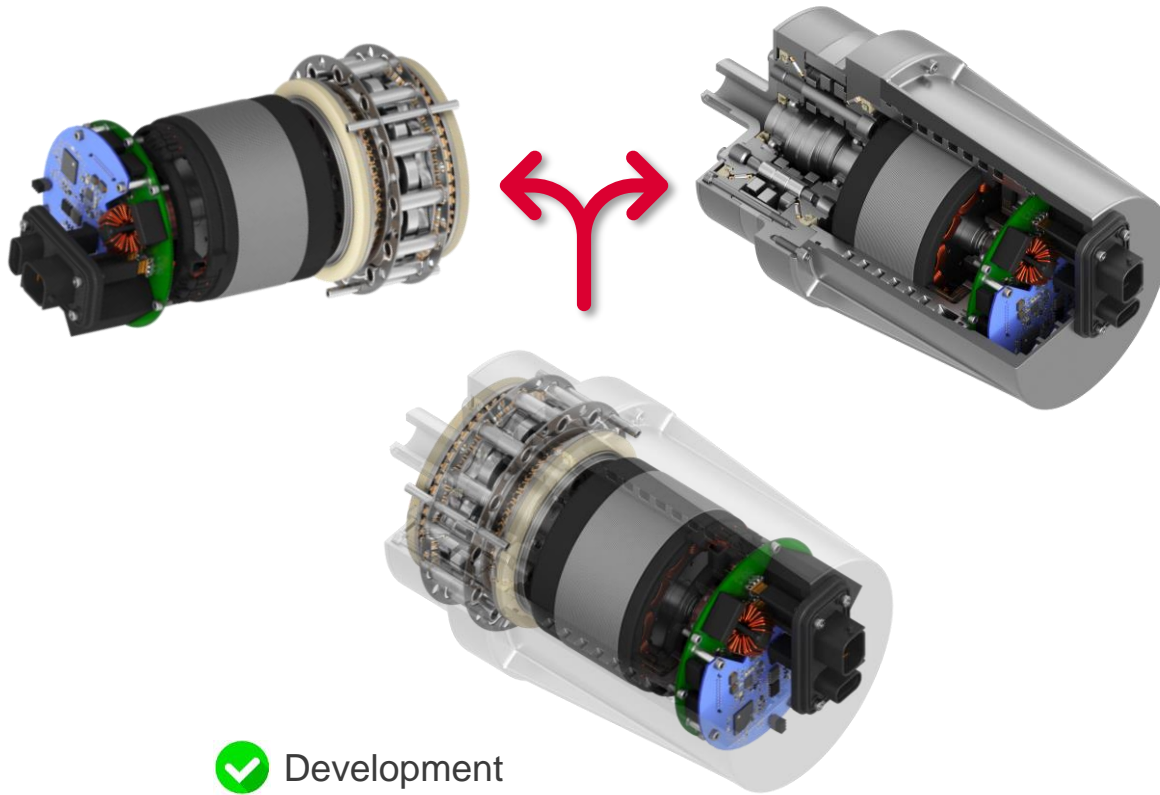

- ✓ Development
- ✓ Prototyping
- ✓ Series production

## Key facts

Drive solutions (small and auxiliary drives) for two-wheelers or industrial trucks with and without transmission gears

- Supply voltage 48-800 V<sub>DC</sub>
- Nominal power 2-30 kW
- Power and control electronics
- High Input Speed (rpm)
- Scalability  $i=11 \rightarrow 200$



- ✓ Development
- ✓ Prototyping
- ✓ Series production

### Key facts

**Drive unit for an electric steering pump in commercial vehicle applications, correspondingly high demands on service life as well as efficiency**

- Power supply 24 V<sub>AC</sub>
- Rated power 4.5 kW
- Max. Flow 130 A
- Housing with A and B end shields and bearings
- Stator pack w. temperature sensor
- Switching ring with seal
- Rotor and shaft with magnetic encode

# iwis mobility systems GmbH & Co. KG

Drive for a compressor unit in the brake system

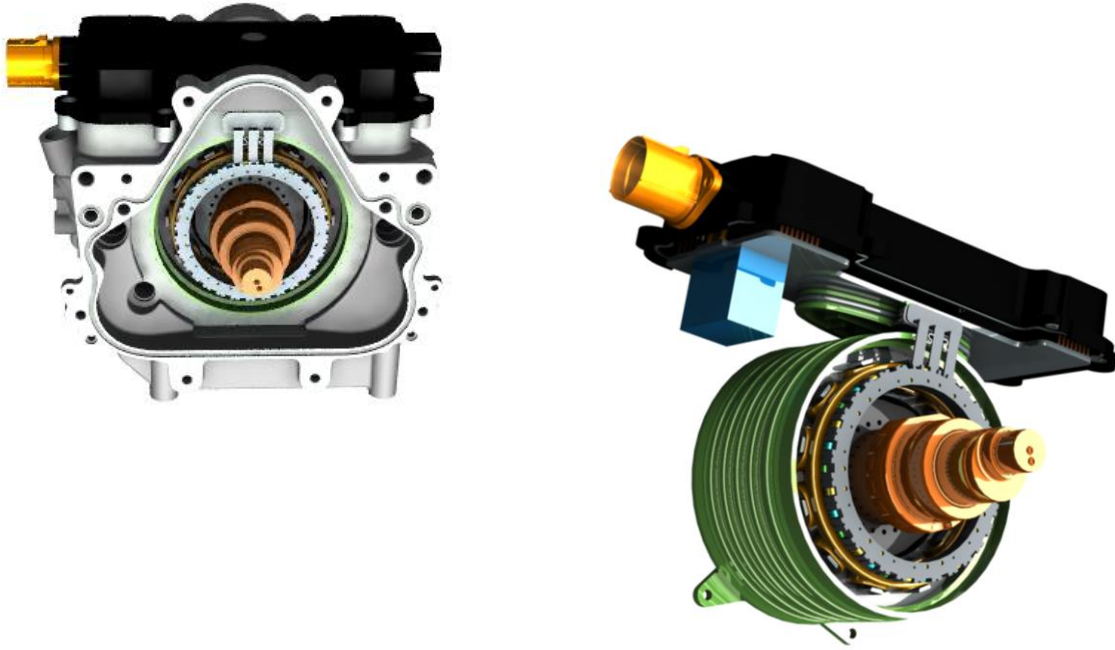

- ✓ Development
- ✓ Prototyping
- ⊘ Series production

## Key facts

Drive for an electric compressor for brake systems in commercial vehicle applications, development of software and electronics including

- Connection voltage 450-800 VAC
- Max. Rated power 4,7 kW
- Max. Flow rate 13 A
- Safety Goal ASIL B
- Cooling jacket, housing
- Drop-in inverter incl. plug connections and cooling siphon
- Switching ring with seal
- Rotor and shaft
- Stator package w. temperature sensor
- Position sensor incl. magnetic ring

# iwis mobility systems GmbH & Co. KG

## Push Pull Chain with e-Drive unit

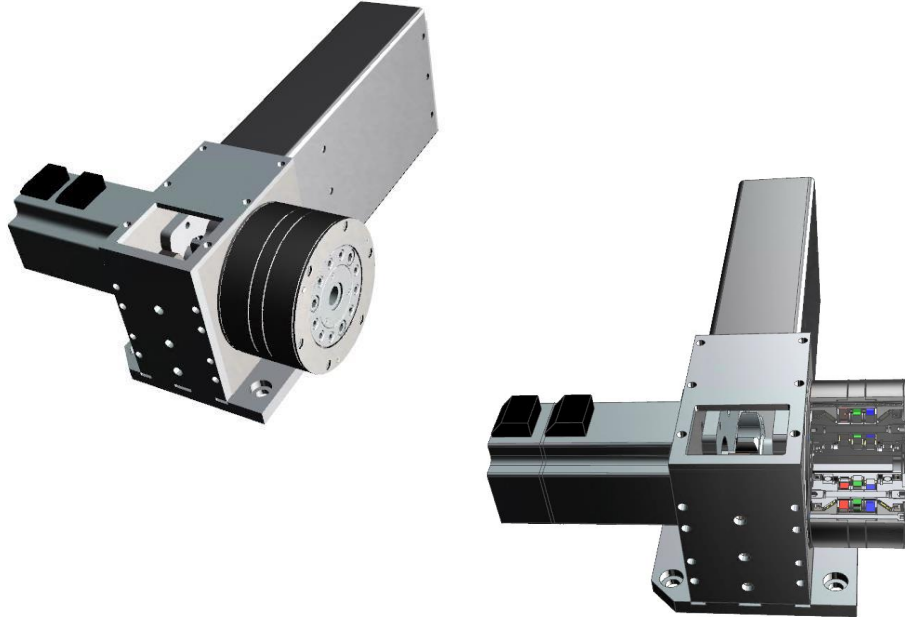

- ✓ Development
- ✓ Prototyping
- ✓ Series production

### Key facts

Drive solution for e.g. lifting table, building technology, logistic systems Integrated electric motor and gearbox

Scalable for different length, weight and speed

E-Motor: EC Series; integrated inverter

Gearbox: High transmission ratio, overload capable

- Supply voltage 48 V<sub>DC</sub>
- Maximum load 1000kg
- Maximum Speed 0,25 m/s
- Maximum lift 1000mm



- ✓ Development
- ✓ Prototyping
- ✓ Series production

### Key facts

**Machine type: Drive system synchronous motor**

Product data:

- Rated power 17 kW
- Peak power 22 kW
- Maximum speed 21,500 rpm
- Power supply 120 - 450 V<sub>DC</sub>
- Dimensions (LxWxH) (180 x 175 x 230) mm
- Mass 14,7 kg → Power to weight ratio 1,16 kW/kg
- Cooling liquid
- Special features
- system efficiency 93 %

# iwis mobility systems GmbH & Co. KG

E-machine for a BEV (test bench)

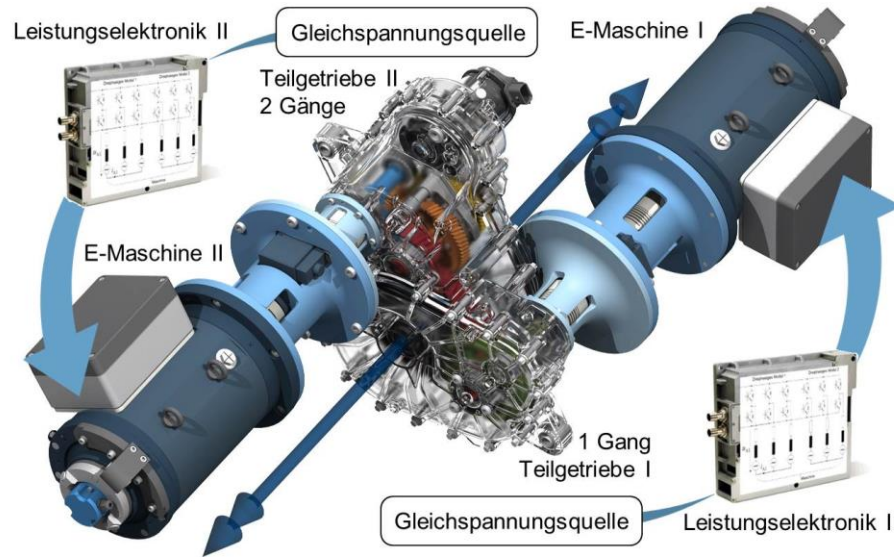

✓ Development

✓ Prototyping

## Key facts

**Machine type: PM machine with buried magnets**

### Product data:

- Nominal power 30 kW
- Peak power 60 kW
- maximum speed 30.000 rpm
- Power supply 800 V<sub>DC</sub>
- Dimensions (LxØxH) (404 x 251 x 332) mm
- Mass 20,0 kg
- Power to weight ratio 1.5 kW/kg
- Cooling Liquid
- Special feature
- Stock selection

# iwis mobility systems GmbH & Co. KG

E-machine for a hybrid vehicle



✓ Development

✓ Prototyping

## Key facts

**Machine type: PM machine with buried magnets**

### Product data:

▪ Nominal power	33 kW
▪ Peak power	56 kW
▪ maximum speed	16.000 rpm
▪ Power supply	300 V <sub>DC</sub>
▪ Dimensions (LxØxH)	300 x 180 x 240 mm
▪ Mass	28.2 kg
▪ Power to weight ratio	1.99 kW/kg
▪ Cooling	Liquid
▪ Special feature	Installation space adaptation

# iwis mobility systems GmbH & Co. KG

Concrete saw for the construction industry



- ✓ Development
- ✓ Prototyping
- ✓ Series production

## Key facts

**Machine type: PM machine with buried magnets**

Product data:

- |                    |              |
|--------------------|--------------|
| ▪ Rated power      | 18 kW        |
| ▪ maximum speed    | 30.000 rpm   |
| ▪ Power supply     | 3 x 300 VAC  |
| ▪ Dimensions (LxØ) | 170 x 105 mm |
| ▪ Mass             | 5,0 kg       |
| ▪ Power to weight  | 3.6 kW/kg    |
| ▪ Cooling          | liquid       |



# iwis mobility systems GmbH & Co. KG

## Synchronous generator



- ✓ Development
- ✓ Prototyping
- ✓ Series production

### Key facts

**Application: Mobile generator for battery charging**

#### Product data:

- Rated power 21.0 kW
- Rated speed 2,800 rpm
- Output voltage 28.3 VDC
- Cooling liquid
- Special features Currents up to 800 Arms  
Operation with rectifier

# iwis mobility systems GmbH & Co. KG

Drive Engine for Compact Loader

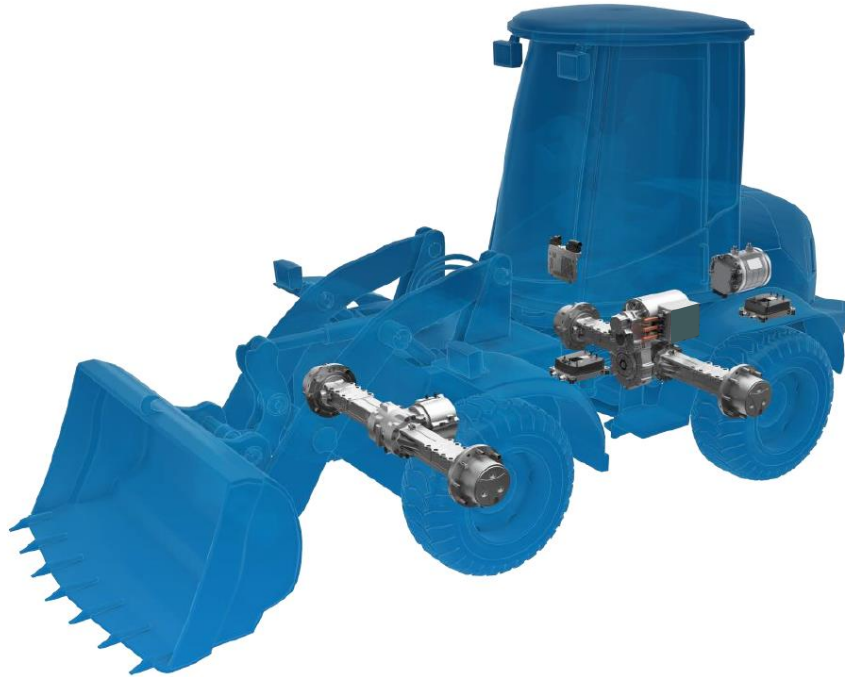

✓ Prototyping

✓ Series production

## Key facts

**Machine type: PM machine with buried magnets**

Product data:

- Max. Torque 130Nm
- Max. power 36 kW
- maximum speed 15.000 rpm
- Power supply 48 VDC
- Dimensions (LxØ) 165 x 210 mm
- Cooling liquid

Further variants under development.

# iwis mobility systems GmbH & Co. KG

## Electrification in Motorcycles

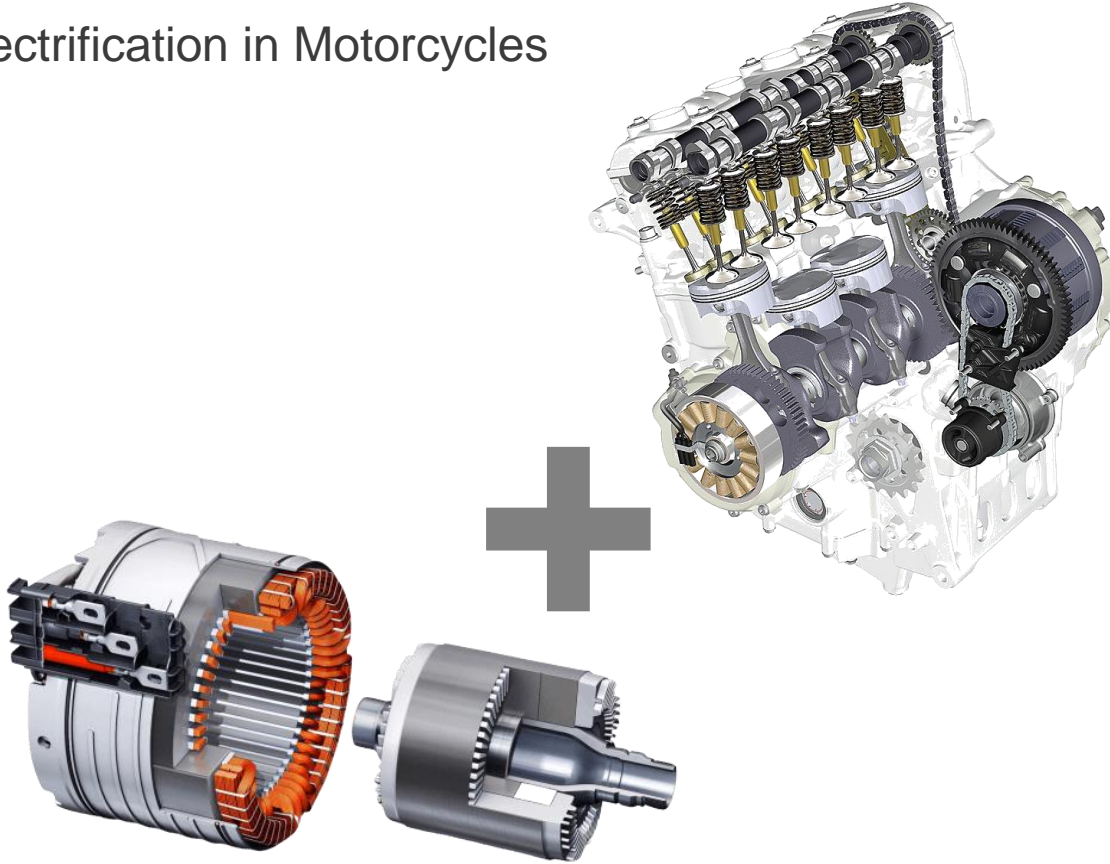

- ✓ Development
- ✓ Prototyping
- ✓ Series production

### Key facts

#### Increased performance – electric power assist

- Higher acceleration
- Reduce response time
- Reduction of part-load-jerk

#### Full electric driving

- Noise reduction
- City mode to fulfil future legislation

#### Emission reduction

- Lower overall emissions

#### Increased efficiency

- Energy restoration with recuperation
- Load point shift

#### Manoeuvring aid

- Reverse gear on steep sections

# iwis mobility systems GmbH & Co. KG

Industrialisation: Built up of E-motor Production in Landsberg



Automatic winding machine in order process for iwis production in Landsberg



EOL station

## Key facts

**Support and Exchange-Program with THIEN eDrives (Testing E-Drives, Prototype-Assembly, Return Part Inspection, Quality Management support)**

### Approach:

- 2022 Production area (1000m<sup>2</sup>) prepared for E/E production
- 2023 Start of stator production at iwis Landsberg (EC-Product-Line) and adaptation/duplication of production line at iwis Landsberg

# Your Contacts:

Thank you for your attention!



## **Dr. Kai Arens**

VP New Business, Strategy and Change  
iwis mobility systems GmbH & Co KG

Albert-Roßhaupter Str. 53  
D-81369 München

E-Mail: [kai.arens@iwis.com](mailto:kai.arens@iwis.com)  
Mobil: +49 151 14717764

## **Peter Bachmair**

Executive Vice President Sales  
iwis mobility systems GmbH & Co KG

Albert-Roßhaupter Str. 53  
D-81369 München

E-Mail: [peter.bachmair@iwis.com](mailto:peter.bachmair@iwis.com)  
Mobil: +49 151 14717680

## **Benjamin Scheffler**

Key Account Manager • DWIL/SI  
iwis antriebssysteme GmbH

Essener Str. 23  
D-57234 Wilnsdorf

E-Mail: [benjamin.scheffler@iwis.com](mailto:benjamin.scheffler@iwis.com)  
Mobil: +49 151 14831067