



Conveyor chain Z100 Bush conveyor chain Z series - ELITE

Part no.: Ifad1faceb30

Brand: ELITE

Model: Bush conveyor chain Z series

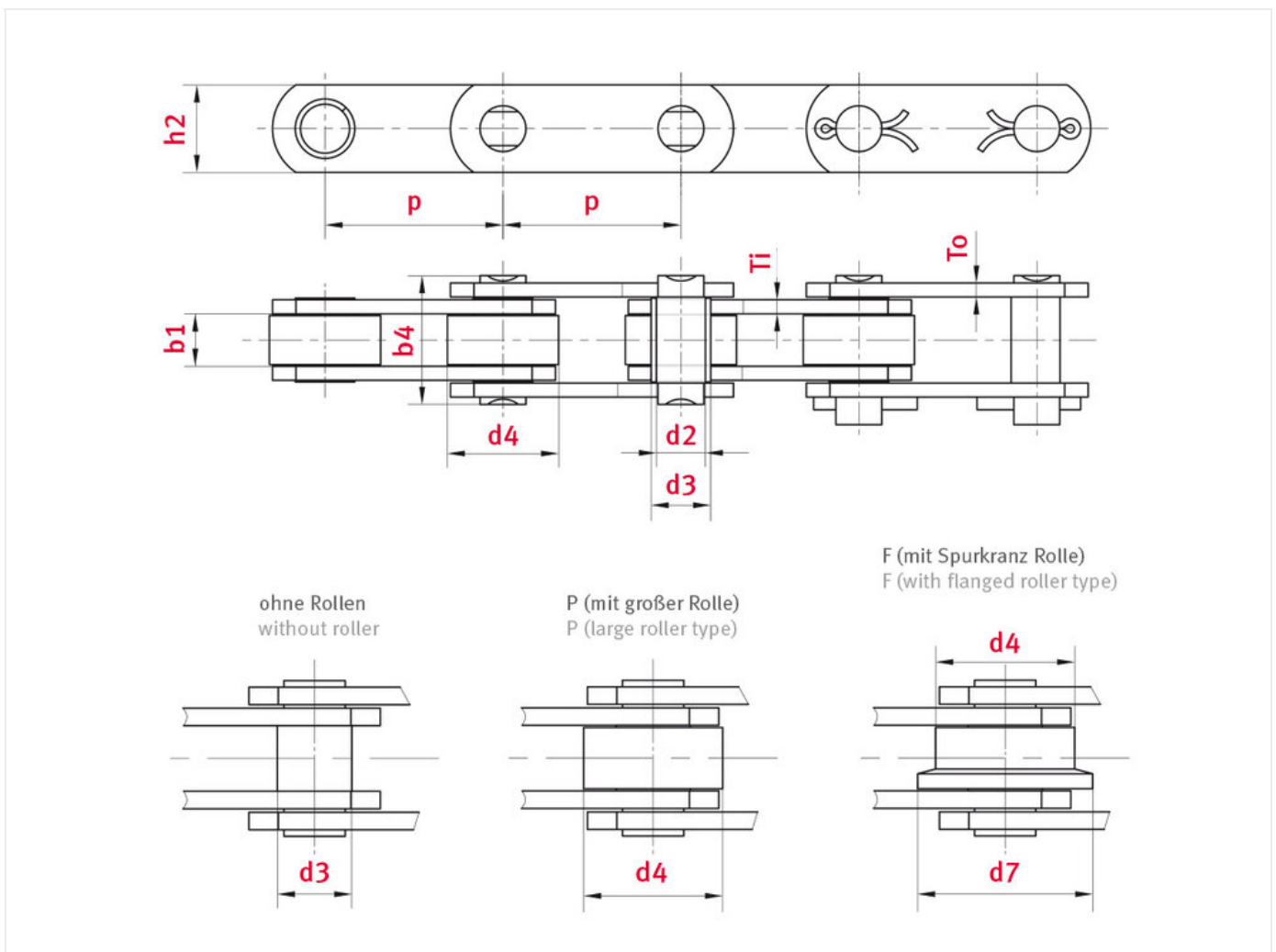

Technical data

ROLLER CHAIN	Z100
Pitch p (mm)	177,8
Width between inner plates b1 min. (mm)	19
Pin diameter d2 max. (mm)	19

Product data

Bush diameter d3 max. (mm)	23
Pin length b4 max. (mm)	50.5
Roller diameter large roller d4 max. (mm)	47.5
Flanged roller diameter d7 (mm)	60
Plate thickness Ti/To (mm)	5/4
Height inner plate h2 max. (mm) (JWIS: g)	40
Min. tensile strength ISO/DIN FU (kN)	100
Bearing surface f (cm ²)	5.5

Product Information

In the context of the ELITE conveyor chain range, iwis supplies a wide variety of chains according to standards DIN 8165 and DIN 8167, as well as models manufactured according to British Standard with dimensions in inches, and highly diverse special versions. Bush conveyor chains are often used for conveying tasks involving long transport distances at relatively low speeds.

ELITE highlights

- Pins usually made of heat-treated alloy steel, induction-hardened
- Bushes made from seamless precision steel tube, case-hardened
- Link plates made of high-strength tempered steel or case-hardened steel alloy
- Rollers (where present) made of case-hardened steel, case-hardened

Applications

- Wood processing industry
- Steelmaking industry
- Automotive industry
- Bulk goods transport
- Environmental technology, Recycling

□

REQUEST DIRECTLY ONLINE NOW

<https://www.iwis.com/en-en/products-services/conveyor-chain-z100-bush-conveyor-chain-z-series-elite~p4508>

Useful information



CALCULATION PROGRAM

InduKet: the Chain Drive
Calculation Program for
Engineers.

iwis.com/chaincalc



CHAIN CALCULATION

The right drive solution for your
challenge.

chaindrive@iwis.com