

Accumulation chain 212B Design LR - JWIS

Part no.: I979266e36d67

Brand: JWIS

Model: Design LR

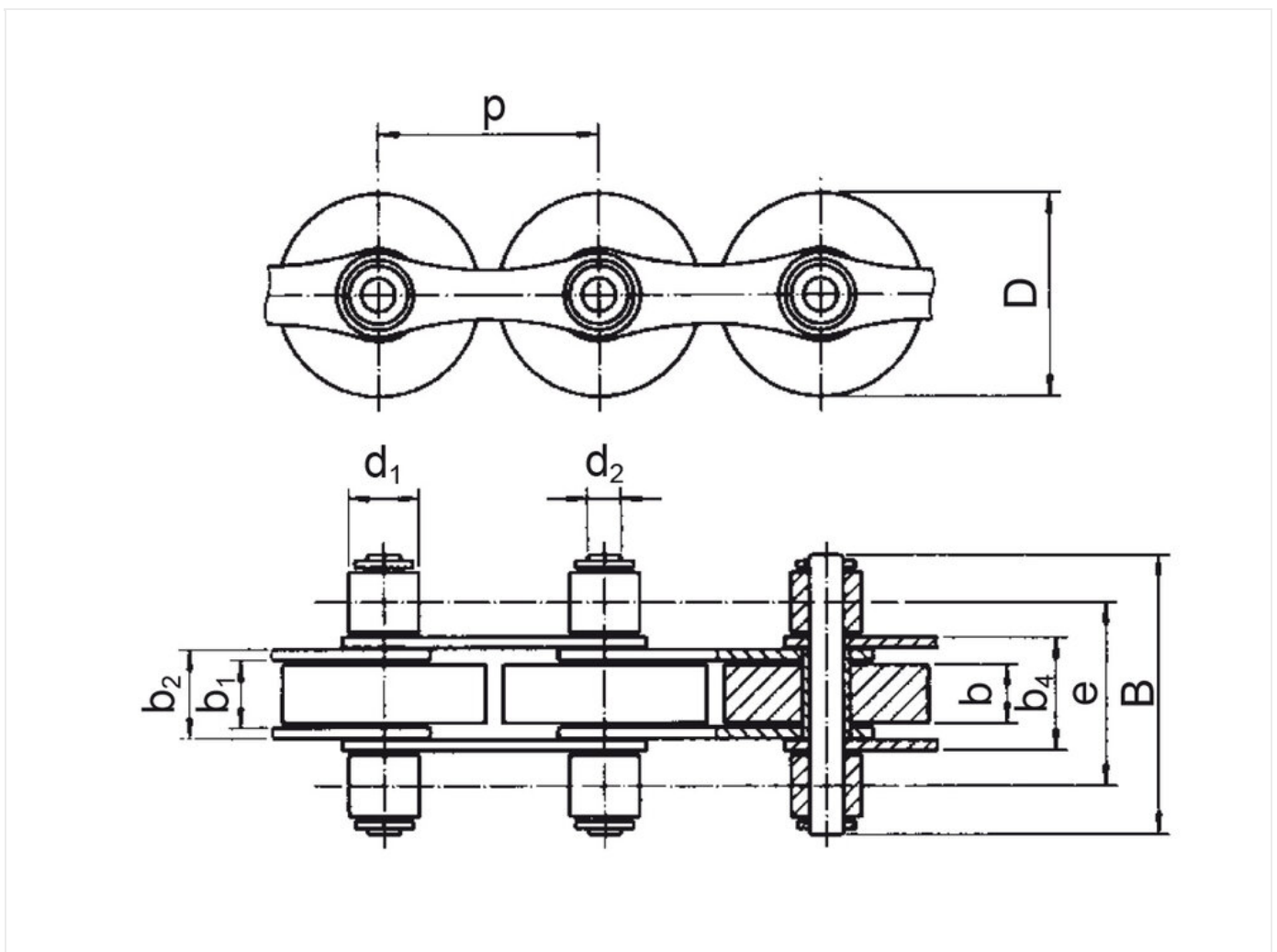

Technical data

ACCUMULATION CHAIN	212B
Pitch p (mm)	38,1
Width between inner plates b1 min. (mm)	11,75
Roller diameter d1 max. (mm)	12,07

Pin diameter d2 max. (mm)	5,72
Pin length b4 max. (mm)	48
Total width inner link b2 max. (mm)	15,62
Width over outer plates b5 max. (mm) (JWIS: b4)	19,55
Conveyer roller diameter d5 (mm) (JWIS: D)	24 / 35
Width over conveyer roller b8 (mm) (JWIS: b)	11
Weight per meter (kg)	2,016
Traverse pitch pt (mm) (JWIS: e)	31,5
Max. load per conveyer roller (N)	15

Product Information

JWIS brand accumulation chains have idler rollers on both sides that serve two purposes: firstly, they engage with the sprocket teeth to transmit power, and secondly, they support the chain in the profile. One special feature are the slightly protruding bushes in the inner link which prevent contact corrosion between inner link and outer plate. All 1/2" and 3/4" JWIS accumulation chains are fitted with low-friction sintered metal rollers that provide consistent and extreme light running and are not slowed down by lubricant. The length of our application conveyor can therefore be built about 30% longer without any need for modification of the drive motors; alternatively, if the system length remains unchanged, smaller drive units may be fitted. Less strain on the chain and drive means a longer service life for the entire conveyor system.

What is special about our IPW-lubricated accumulation chains:

- iwis accumulation chains are dry on the outside
- Conveyed goods do not come into contact with lubricant
- No risk of over-lubrication, so no oil can splash or drip in sensitive areas
- Surrounding area is guaranteed to stay clean
- No dirt, particles, fibres or dust can adhere to the chain

Applications

- Warehouse technology, materials-handling industry
- Electronics industry and PCB manufacture
- Conveyor technology
- Packaging industry
- Food processing industry
- Glass, ceramic and building material industry
- Pharmaceutical industry, medical technology

REQUEST DIRECTLY ONLINE NOW

<https://www.iwis.com/en-en/products-services/accumulation-chain-212b-design-lr-jwis~p4938>

Useful information

CALCULATION PROGRAM

InduKet: the Chain Drive Calculation Program for Engineers.

[iwis.com/chaincalc](https://www.iwis.com/chaincalc)

CHAIN CALCULATION

The right drive solution for your challenge.

chaindrive@iwis.com

SERVICES

ChainFinder, CAD data, iwis Chain Handbook and more.

[iwis.com/services](https://www.iwis.com/services)